

High Grade Low Speed Axial Crusher

			SX-110	SX-160	SX-250	SX-340
Body opening dimensions	mm		112 x 118	160 x 170	254 x 230	338 x 330
Loading port dimensions	mm		130 x 120	163 x 176	254 x 234	338 x 334
Drive system	Directly coupled geared motor					
Crushing mechanism	Coaxial crushing and pulverizing					
Rotating speed (50/60Hz)	rpm		18.8 / 22.5	18.8 / 22.5	18.8 / 22.5	18.8 / 22.5
Large rotating blade dia.	mm		100	160	209	300
Small rotating blade dia.	mm		55	80	105	105
Stationary crusher blade size (WxD)	mm		3 x 3	4 x 4	5 x 5	5 x 5
Tank capacity	Suction tank (Type S)	L	0.9	2.3	7.6	23.3
	Stock tank (Type T)	L	1.7	4.3	12.8	53.2
Power	Total electric capacity (50/60Hz)	kVA	0.42 / 0.38	0.80 / 0.69	1.32 / 1.18	2.41 / 2.18
	Power consumption	kW	0.2	0.4	0.75	1.5
	Power supply standard	200 / 220V 50 / 60Hz 3ø				
	Power plug	20A-3P plug with protective ground				
Outer dimensions (Same for all tanks)	W1	mm	475	590	805	995
	W2	mm	620	730	995	1,210
	D1	mm	316	340	425	515
	D2	mm	425	620	830	1,110
	H	mm	680	840	1,105	1,395
Weight	kg		46	90	180	300
Accessories	Coupler handle for manual turning					

Outer dimensions

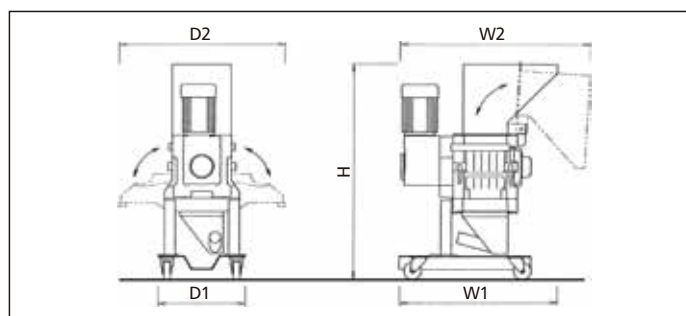

- Tank can be selected between an Suction tank (Type S) and Stock tank (Type T).
- Specifications are subject to change without notice.